

Technical Specification UTM 1200



ADVANTAGES

High capacity up to 150 t/h

Low air pollution

Low noise pollution

No vibrations

Low wear costs and maintenance

Changing all the cutting tools on the shafts only takes a few hours.

Hydraulic setting adjustment

All specifications subject to change without prior notice.



CAMS s.r.l.

VIA Giulio Golini, 301 40024- Castel San Pietro Terme (BO)- Tel. 0516946611
Cod. Fisc. e Part. IVA 02146431206- R.E.A. n° 416377- Cap. Soc. 93.000 euro Int. Vers.

FEATURES

Shredder

- Type of Shredder FTR 1200
- Feed opening mm 1200x900
- Max feed size mm 600x350x300
- Electric motor kW 37 (18,5+18,5)
- Rotors speed rpm 10
- Max Capacity t/h 150
- Weight Kg 9.000
- V belts and pulleys
- Chuteworks

Feeding Hopper

- Capacity : m³ 3,20
- Length : m 3,20
- Width : m 2,00

Main Conveyor TNL 800x7,00 m

- Length m 7,00
- Belt width mm 800
- Belt speed m/s 1,4
- Capacity t/h 150
- Electric moto-reducer kW 5,5
- Height discharge m 3,00
- Hydraulically Folding

Overband Magnet

- Conveyor Length mm 1660
- Belt width mm 650
- Magnet mm 800x600
- Power 420 Gauss at 200 mm
- Electric moto-reducer kW 1,5

Track data

- Track Length mm 3550
- Track width mm 400
- Hydraulic Motor Rexroth
- Gearbox Trasmital
- Speed Km/h 0,4÷0,7
- Control: Remote handset – Dual Speed

All specifications subject to change without prior notice.



CAMS s.r.l.

**VIA Giulio Golini, 301 40024- Castel San Pietro Terme (BO)- Tel. 0516946611
Cod. Fisc. e Part. IVA 02146431206- R.E.A. n° 416377- Cap. Soc. 93.000 euro Int. Vers.**

Genset

- Diesel Engine: IVECO FPT N45 100 kW at 1500 rpm
- Alternator: M.E.C.C. ALTE 138 kVA
- Hydraulic Tank: lt. 90
- Fuel Tank: lt. 170

Chassis

Heavy duty fabricated I section of welded construction

Transport Dimension:

- Width m 2,55
- Height m 3,00
- Length m 10,30
- Weight Kg 20.000

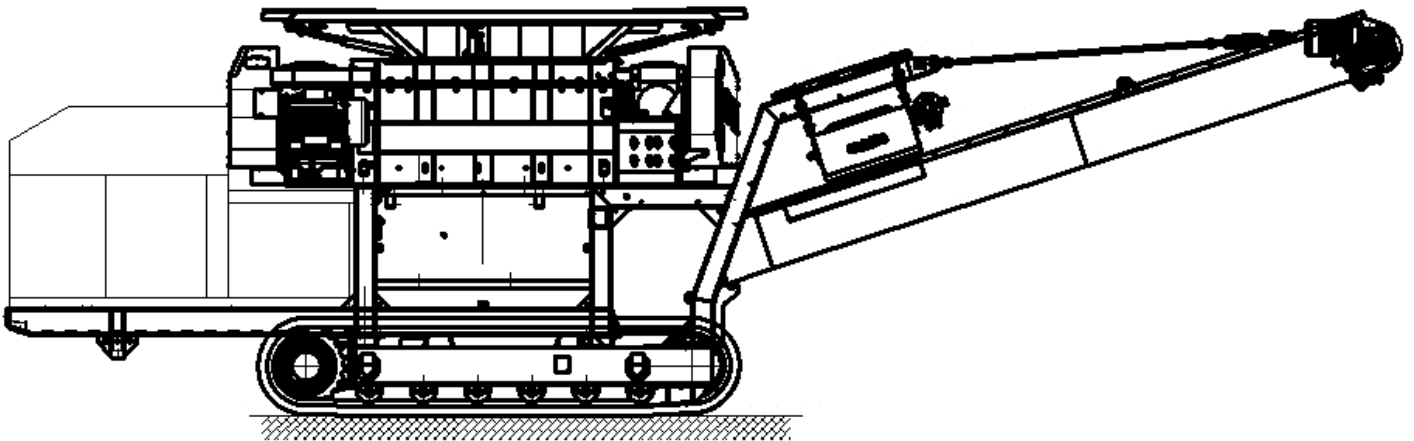

All specifications subject to change without prior notice.



CAMS s.r.l.
VIA Giulio Golini, 301 40024- Castel San Pietro Terme (BO)- Tel. 0516946611
Cod. Fisc. e Part. IVA 02146431206- R.E.A. n° 416377- Cap. Soc. 93.000 euro Int. Vers.